

Pressure Booster System

Installation/Operating Manual

Hydro-Unit Base Line economy

Hydro-Unit Base Line economy MVP



CE

Legal information/Copyright

Original operating manual Hydro-Unit Base Line economy

All rights reserved. The contents provided herein must neither be distributed, copied, reproduced, edited or processed for any other purpose, nor otherwise transmitted, published or made available to a third party without the manufacturer's express written consent.

Subject to technical modification without prior notice.

© Duijvelaar Pompen B.V., Alphen aan den Rijn, Netherlands 2023-05-26

Contents

	Glossary	5
1	General	6
	1.1 Principles	6
	1.2 Software changes	6
	1.3 Installation of partly completed machinery.....	6
	1.4 Target group	6
	1.5 Other applicable documents	6
	1.6 Symbols	6
	1.7 Key to safety symbols/markings	7
2	Safety	8
	2.1 General	8
	2.2 Intended use	8
	2.3 Personnel qualification and personnel training	9
	2.4 Consequences and risks caused by non-compliance with this manual	9
	2.5 Safety awareness	9
	2.6 Safety information for the operator/user	9
	2.7 Safety information for maintenance, inspection and installation	10
	2.8 Unauthorised modes of operation.....	10
	2.9 Electromagnetic compatibility (EMC).....	10
	2.9.1 Interference emission requirements	10
	2.9.2 Line harmonics requirements	11
	2.9.3 Interference immunity requirements.....	11
3	Transport/Storage/Disposal	13
	3.1 Checking the condition upon delivery	13
	3.2 Transport.....	13
	3.3 Storage/preservation	13
	3.4 Return to supplier	14
	3.5 Disposal	14
4	Description	16
	4.1 General description.....	16
	4.2 Product information as per Regulation No. 1907/2006 (REACH).....	16
	4.3 Designation	16
	4.4 Name plate	16
	4.5 Design details	17
	4.6 Configuration and function	18
	4.7 Noise characteristics.....	19
	4.8 Scope of supply	19
	4.8.1 Inlet conditions, version M.....	19
	4.8.2 Inlet conditions, version F.....	20
	4.8.3 Inlet conditions, version L.....	21
	4.9 Dimensions and weight.....	22
	4.10 Terminal wiring diagram.....	22
	4.11 Potential equalisation.....	22
5	Installation at Site	24
	5.1 Installation.....	24
	5.2 Checks to be carried out prior to installation.....	24
	5.3 Installing the pressure booster system	25



5.4	Connecting the piping	25
5.4.1	Fitting an expansion joint.....	26
5.5	Installing unpressurised inlet tanks	26
5.6	Electrical connection	27
5.6.1	Sizing the power cable	27
5.6.2	Connecting the external dry running protection device (optional)	27
6	Commissioning/Start-up/Shutdown	28
6.1	Commissioning/Start-up	28
6.1.1	Prerequisites for commissioning/start-up	28
6.1.2	Commissioning/start-up of pressure booster system	28
6.2	Switching on the pressure booster system	29
6.3	Checklist for commissioning/start-up	29
6.4	Shutdown	29
6.5	Shutdown	30
6.5.1	Shutdown	30
6.5.2	Measures to be taken for shutdown	31
7	Operating the Pressure Booster System.....	32
7.1	Design of the frequency inverter	32
7.1.1	Display of the frequency inverter, start view.....	33
7.2	Pressure booster systems with configured frequency inverter drives.....	34
7.3	Programming	34
8	Servicing/Maintenance	36
8.1	General information/Safety regulations	36
8.2	Servicing/inspection	37
8.2.1	Supervision of operation.....	37
8.2.2	Maintenance schedule	37
8.2.3	Setting the pre-charge pressure.....	38
9	Trouble-shooting	39
10	Related Documents	41
10.1	General assembly drawings/exploded views with list of components	41
10.1.1	Hydro-Unit Base Line economy MVP	41
11	EU Declaration of Conformity	42
12	Certificate of Decontamination	43
13	Commissioning Report	44
	Index.....	45

Glossary

Accumulator

Pressure losses may occur in the piping downstream of the pressure booster system as a result of losses due to leakage. The accumulator serves to compensate for pressure losses and minimises the frequency of starts of the pressure booster system.

Certificate of decontamination

A certificate of decontamination is enclosed by the customer when returning the product to the manufacturer to certify that the product has been properly drained to eliminate any environmental and health hazards arising from components in contact with the fluid handled.

Dry running protection

Dry running protection devices prevent the pump from being operated without the fluid to be handled, which would result in pump damage.

IE3

Efficiency class to IEC 60034-30: 3 = Premium Efficiency (IE = International Efficiency)

1 General

1.1 Principles

This operating manual is valid for the type series and variants indicated on the front cover.

The operating manual describes the proper and safe use of this equipment in all phases of operation.

The name plate indicates the type series, the main operating data and the serial number. The serial number uniquely describes the product and is used as identification in all further business processes.

In the event of damage, immediately contact your nearest DP service facility to maintain the right to claim under warranty.

1.2 Software changes

The software has been specially created for this product and thoroughly tested. Making changes or additions to the software or parts of the software is prohibited. This does not, however, apply to software updates by DP .

1.3 Installation of partly completed machinery

To install partly completed machinery supplied by DP refer to the sub-sections under Servicing/Maintenance.

1.4 Target group

This operating manual is aimed at the target group of trained and qualified specialist technical personnel. [⇒ Section 2.3, Page 9]

1.5 Other applicable documents

Table 1: Overview of other applicable documents

Document	Contents
Sub-supplier product literature	Operating manuals, circuit diagram and other product literature describing accessories and integrated machinery components







1.6 Symbols

Table 2: Symbols used in this manual

Symbol	Description
✓	Conditions which need to be fulfilled before proceeding with the step-by-step instructions
▷	Safety instructions
⇒	Result of an action
⇔	Cross-references
1. 2.	Step-by-step instructions
	Note Recommendations and important information on how to handle the product

1.7 Key to safety symbols/markings

Table 3: Definition of safety symbols/markings

Symbol	Description
 DANGER	DANGER This signal word indicates a high-risk hazard which, if not avoided, will result in death or serious injury.
 WARNING	WARNING This signal word indicates a medium-risk hazard which, if not avoided, could result in death or serious injury.
 CAUTION	CAUTION This signal word indicates a hazard which, if not avoided, could result in damage to the machine and its functions.
	General hazard In conjunction with one of the signal words this symbol indicates a hazard which will or could result in death or serious injury.
	Electrical hazard In conjunction with one of the signal words this symbol indicates a hazard involving electrical voltage and identifies information about protection against electrical voltage.
	Machine damage In conjunction with the signal word CAUTION this symbol indicates a hazard for the machine and its functions.

2 Safety



DANGER

All the information contained in this section refers to hazardous situations.

In addition to the present general safety information the action-related safety information given in the other sections must be observed.

2.1 General

- This operating manual contains general installation, operating and maintenance instructions that must be observed to ensure safe operation of the system and prevent personal injury and damage to property.
- Comply with all the safety instructions given in the individual sections of this operating manual.
- The operating manual must be read and understood by the responsible specialist personnel/operators prior to installation and commissioning.
- The contents of this operating manual must be available to the specialist personnel at the site at all times.
- Information and markings attached directly to the product must always be complied with and kept in a perfectly legible condition at all times. This applies to, for example:
 - Arrow indicating the direction of rotation
 - Markings for connections
 - Name plate
- The operator is responsible for ensuring compliance with all local regulations not taken into account.

2.2 Intended use

- The pressure booster system must only be operated within the operating limits described in the other applicable documents.
- Only operate pressure booster systems which are in perfect technical condition.
- Do not operate partially assembled pressure booster systems.
- The pressure booster system must only handle the fluids described in the product literature of the respective design variant.
- Never operate the pressure booster system without the fluid to be handled.
- Observe the information on minimum flow rates specified in the product literature (to prevent overheating, bearing damage, etc).
- Observe the maximum flow rates indicated in the data sheet or product literature (to prevent overheating, cavitation damage, bearing damage, etc).
- Do not throttle the flow rate on the suction side of the pressure booster system (to prevent cavitation damage).
- Consult the manufacturer about any other modes of operation not described in the product literature.

2.3 Personnel qualification and personnel training

- All personnel involved must be fully qualified to install, operate, maintain and inspect the product this manual refers to.
- The responsibilities, competence and supervision of all personnel involved in transport, installation, operation, maintenance and inspection must be clearly defined by the operator.
- Deficits in knowledge must be rectified by means of training and instruction provided by sufficiently trained specialist personnel. If required, the operator can commission the manufacturer/supplier to train the personnel.
- Training on the pressure booster system must always be supervised by specialist technical personnel.

2.4 Consequences and risks caused by non-compliance with this manual

- Non-compliance with these operating instructions will lead to forfeiture of warranty cover and of any and all rights to claims for damages.
- Non-compliance can, for example, have the following consequences:
 - Hazards to persons due to electrical, thermal, mechanical and chemical effects and explosions
 - Failure of important product functions
 - Failure of prescribed maintenance and servicing practices
 - Hazard to the environment due to leakage of hazardous substances

2.5 Safety awareness

In addition to the safety information contained in this operating manual and the intended use, the following safety regulations shall be complied with:

- Accident prevention, health regulations and safety regulations
- Explosion protection regulations
- Safety regulations for handling hazardous substances
- Applicable standards, directives and laws

2.6 Safety information for the operator/user

- Fit protective equipment (e.g. contact guards) supplied by the operator for hot, cold or moving parts, and check that the equipment functions properly.
- Do not remove any protective equipment (e.g. contact guards) during operation.
- Eliminate all electrical hazards. (In this respect refer to the applicable national safety regulations and/or regulations issued by the local energy supply companies.)
- If stopping the pump does not increase potential risk, fit an emergency-stop control device in the immediate vicinity of the pump (set) during pump set installation.

2.7 Safety information for maintenance, inspection and installation

- Modifications or alterations of the pressure booster system are only permitted with the manufacturer's prior consent.
- Use only original spare parts or parts authorised by the manufacturer. The use of other parts can invalidate any liability of the manufacturer for resulting damage.
- The operator ensures that maintenance, inspection and installation are performed by authorised, qualified specialist personnel who are thoroughly familiar with the manual.
- Carry out work on the pressure booster system during standstill only.
- The pump casing must have cooled down to ambient temperature.
- Pump pressure must have been released and the pump must have been drained.
- When taking the pressure booster system out of service always adhere to the procedure described in the manual.
- Decontaminate pressure booster systems which handle fluids posing a health hazard.
- As soon as the work has been completed, re-install and/or re-activate any safety-relevant and protective devices. Before returning the product to service, observe all instructions on commissioning.
- Make sure the pressure booster system cannot be accessed by unauthorised persons (e.g. children).
- Prior to opening the device, pull the mains plug and wait for at least 10 minutes.

2.8 Unauthorised modes of operation

Always observe the limits stated in the product literature.

The warranty relating to the operating reliability and safety of the pressure booster system supplied is only valid if the equipment is used in accordance with its intended use.

[⇒ Section 2.2, Page 8]

2.9 Electromagnetic compatibility (EMC)

2.9.1 Interference emission requirements

The EN 61800-3 EMC product standard is relevant for electric variable speed drives/control systems. It specifies all pertinent requirements and refers to the relevant generic standards for complying with the EMC Directive.

Frequency inverters are commonly used by operators as a part of a system, plant or machine assembly. It should be noted that the operator bears all responsibility for the final EMC properties of the equipment, plant or installation.

A prerequisite or requirement for complying with the relevant standards or the limit values and inspection/test levels referenced by them is that all information and descriptions regarding EMC-compliant installation be observed and followed.

In accordance with the EMC product standard, the EMC requirements to be met depend on the purpose or intended use of the frequency inverter. Four categories are defined in the EMC product standard:

Table 4: Categories of intended use

Category	Definition	Limits to EN 55011
C1	Frequency inverters with a supply voltage under 1000 V installed in the first environment (residential and office areas).	Class B
C2	Frequency inverters with a supply voltage under 1000 V installed in the first environment (residential and office areas) that are neither ready to be plugged in/ connected nor are mobile and must be installed and commissioned by specialist personnel.	Class A, Group 1
C3	Frequency inverters with a supply voltage under 1000 V installed in the second environment (industrial environments).	Class A, Group 2
C4	Frequency inverters with a supply voltage over 1000 V and a nominal current over 400 A installed in the second environment (industrial environments) or that are envisaged for use in complex systems.	No borderline/ boundary ¹⁾

The following limit values and inspection/test levels must be complied with if the generic standard on interference emissions applies:

Table 5: Classification of installation environment

Environment	Generic standard	Limits to EN 55011
First environment (residential and office areas)	EN/IEC 61000-6-3 for private, business and commercial environments	Class B
Second environment (industrial environments)	EN/IEC 61000-6-4 for industrial environments	Class A, Group 1

The frequency inverter meets the following requirements:

Table 6: EMC properties of the frequency inverter

Power [kW]	Cable length [m]	Category to EN 61800-3	Limits to EN 55011
≤ 11	≤ 5	C1	Class B

The EN 61800-3 standard requires that the following warning be provided for drive systems that do not comply with category C1 specifications:

This product can produce high-frequency interference emissions that may necessitate targeted interference suppression measures in a residential or office environment.

2.9.2 Line harmonics requirements

The product is a device for professional applications as defined by EN 61000-3-2. The following generic standards apply when establishing a connection to the public power grid:

- EN 61000-3-2 for symmetric, three-phase devices (professional devices with a total power of up to 1 kW)
- EN 61000-3-12 for devices with a phase current of between 16 A and 75 A and professional devices from 1 kW up to a phase current of 16 A.

2.9.3 Interference immunity requirements

In general, the interference immunity requirements for a frequency inverter hinge on the specific environment in which the inverter is installed.

The requirements for industrial environments are therefore higher than those for residential and office environments.

The frequency inverter is designed such that the immunity requirements for industrial environments and, thus, the lower-level requirements for residential and office environments, are met and fulfilled.

¹ An EMC plan must be devised.

The following relevant generic standards are used for the interference immunity test:

- EN 61000-4-2: Electromagnetic compatibility (EMC)
 - Part 4-2: Testing and measurement techniques – Electrostatic discharge immunity test
- EN 61000-4-3: Electromagnetic compatibility (EMC)
 - Part 4-3: Testing and measurement techniques – Radiated, radio-frequency, electromagnetic field immunity test
- EN 61000-4-4: Electromagnetic compatibility (EMC)
 - Part 4-4: Testing and measurement techniques – Electrical fast transient/burst immunity test
- EN 61000-4-5: Electromagnetic compatibility (EMC)
 - Part 4-5: Testing and measurement techniques – Surge immunity test
- EN 61000-4-6: Electromagnetic compatibility (EMC)
 - Part 4-6: Testing and measurement techniques – Immunity to conducted disturbances, induced by radio-frequency fields

3 Transport/Storage/Disposal

3.1 Checking the condition upon delivery

1. On transfer of goods, check each packaging unit for damage.
2. In the event of in-transit damage, assess the exact damage, document it and notify DP or the supplying dealer and the insurer about the damage in writing immediately.

3.2 Transport

	<p>⚠ DANGER Pressure booster system tipping over Danger to life from falling pressure booster system!</p> <ul style="list-style-type: none">▷ Never suspend the pressure booster system by its power cable.▷ Do not lift the pressure booster system by its manifold.▷ Observe the applicable local accident prevention regulations.▷ Observe the information on weights, centre of gravity and fastening points.▷ Use suitable and permitted transport equipment, e.g. crane, forklift or pallet jack.
-----------------------------------------------------------------------------------	---------------------------------------------------------------------------------------------------------------------------------------------------------------------------------------------------------------------------------------------------------------------------------------------------------------------------------------------------------------------------------------------------------------------------------------------------------------------------------------------------------------------------------------------------------------------------------

- ✓ Transport equipment / lifting equipment suitable for the corresponding weight has been selected and is on hand.
1. Remove the packaging. Remove the caps from the connection openings.
 2. Check for any in-transit damage.
 3. Transport the pressure booster system to the place of installation.
 4. Detach the pressure booster system from the pallet using a suitable tool.
 5. Separate the pressure booster system from the wooden skids with a suitable tool. Lift the pressure booster system off. Dispose of the wooden skids.
 6. Carefully place down the pressure booster system at the site of installation.

3.3 Storage/preservation

	<p>CAUTION Damage during storage due to frost, moisture, dirt, UV radiation or vermin Corrosion/contamination of pressure booster system!</p> <ul style="list-style-type: none">▷ Store the pressure booster system in a frost-proof room. Do not store outdoors.
-------------------------------------------------------------------------------------	-------------------------------------------------------------------------------------------------------------------------------------------------------------------------------------------------------------------------------------------------------------------------------------------------------

	<p>CAUTION Wet, contaminated or damaged openings and connections Leakage or damage of the pressure booster system!</p> <ul style="list-style-type: none">▷ Only open the openings of the pressure booster system at the time of installation.
-------------------------------------------------------------------------------------	-----------------------------------------------------------------------------------------------------------------------------------------------------------------------------------------------------------------------------------------------------------------------------------

	<p>NOTE Rotate the shaft by hand every three months, e.g. via the motor fan.</p>
-------------------------------------------------------------------------------------	---------------------------------------------------------------------------------------------

If commissioning is to take place some time after delivery, the following measures are recommended when storing the pressure booster system:

Store the pressure booster system in a dry, protected room where the atmospheric humidity is as constant as possible.

Table 7: Ambient conditions for storage

Ambient condition	Value
Relative humidity	50 % maximum
Ambient temperature	0 °C to +40 °C

- Frost-free
- Well-ventilated

3.4 Return to supplier

1. Drain the pressure booster system as per operating instructions.
2. Always flush and clean the pressure booster system, particularly if it has been used for handling noxious, explosive, hot or other hazardous fluids.
3. If the pressure booster system has handled fluids whose residues could lead to corrosion damage in the presence of atmospheric humidity or could ignite upon contact with oxygen, the pressure booster system must also be neutralised, and anhydrous inert gas must be blown through the pressure booster system to ensure drying.
4. Always complete and enclose a certificate of decontamination when returning the pressure booster system. [⇒ Section 12, Page 43]
Always indicate any safety and decontamination measures taken.



NOTE

If required, a blank certificate of decontamination can be downloaded from the following web site: www.dp.nl/certificates-of-decontamination

3.5 Disposal



⚠ WARNING

Fluids handled, consumables and supplies which are hot and/or pose a health hazard

Hazard to persons and the environment!

- Collect and properly dispose of flushing fluid and any fluid residues.
- Wear safety clothing and a protective mask if required.
- Observe all legal regulations on the disposal of fluids posing a health hazard.

1. Dismantle the pressure booster system.
Collect greases and other lubricants during dismantling.
2. Separate and sort the pump materials, e.g. by:
 - Metals
 - Plastics
 - Electronic waste
 - Greases and other lubricants
3. Dispose of materials in accordance with local regulations or in another controlled manner.

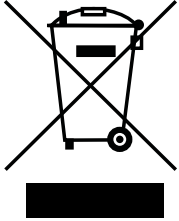

Electrical or electronic equipment marked with the adjacent symbol must not be disposed of in household waste at the end of its service life.

Contact your local waste disposal partner for returns.

If the used electrical or electronic equipment contains personal data, the operator is responsible for deleting it before the equipment is returned.

4 Description

4.1 General description

- Pressure booster system

4.2 Product information as per Regulation No. 1907/2006 (REACH)

For information as per chemicals Regulation (EC) No. 1907/2006 (REACH), see <http://www.dp.nl/reach>.

4.3 Designation

Example: HU2 Base Line economy DPHM 6/6 B MVP

Table 8: Designation key

Code	Description
HU	Hydro-Unit
2	Number of pumps
Base Line economy	Type series
DPHM 6	Size
	DPHM 6
6 B	Number of stages
MVP	Design
	MVP
	Variable speed pressure booster system

4.4 Name plate

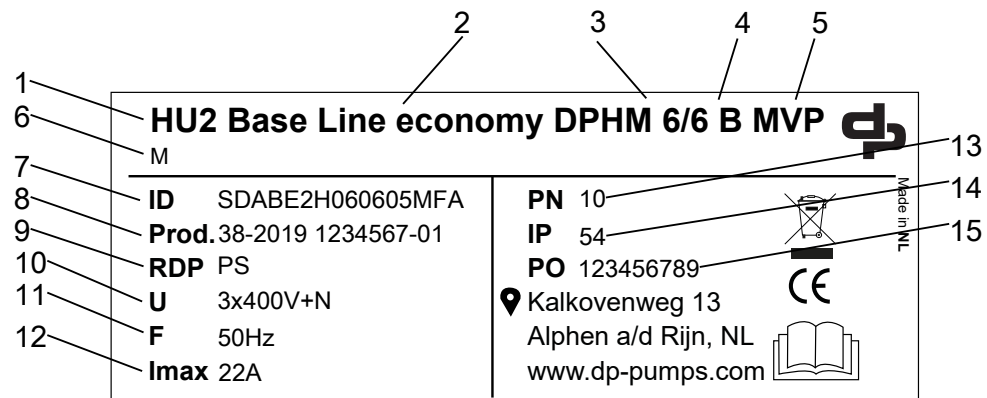

Fig. 1: Name plate (example)

1	Number of pumps	9	Dry running protection
2	Type series	10	Power supply voltage
3	Size	11	Power supply frequency
4	Number of stages	12	Maximum current input
5	Design	13	Max. operating pressure

6	Inlet conditions ²⁾	14	Enclosure
7	Serial number	15	Order number
8	Month of production / year of production, consecutive number		

4.5 Design details

Design

- Fully automatic pressure booster package system
- 2 horizontal centrifugal pumps with frequency inverters
- Baseplate-mounted
- Membrane-type accumulator (direct-flow) to DIN 4807-5 on the discharge side, approved for drinking water, with shut-off element and drain valve.
- Discharge-side gate valve per pump
- Pressure gauge

For inlet conditions F and M only:

- Check valve per pump
- Suction side ball valve or shut-off butterfly valve per pump

Installation

- Stationary dry installation

Drive

- Three-phase motor
- To IEC 60034-7
- Efficiency class IE3 to IEC 60034-30 (for three-phase motors ≥ 0.75 kW)
- Frequency 50 Hz/60 Hz (pump frequency = 50 Hz)
- Enclosure IP55

Automation

- Frequency inverter for speed control, IP55, for pressure-controlled starting and stopping
- Function/fault indicated
- Setting the pressure via buttons or via bluetooth using an app
- Dry running protection

²⁾ M = Inlet side of pressure booster system connected to the municipal water supply, suction head operation F = Pressure booster system with break tank arranged on same level as pump, suction head operation L = Pressure booster system with break tank arranged at a lower level, suction lift operation

4.6 Configuration and function

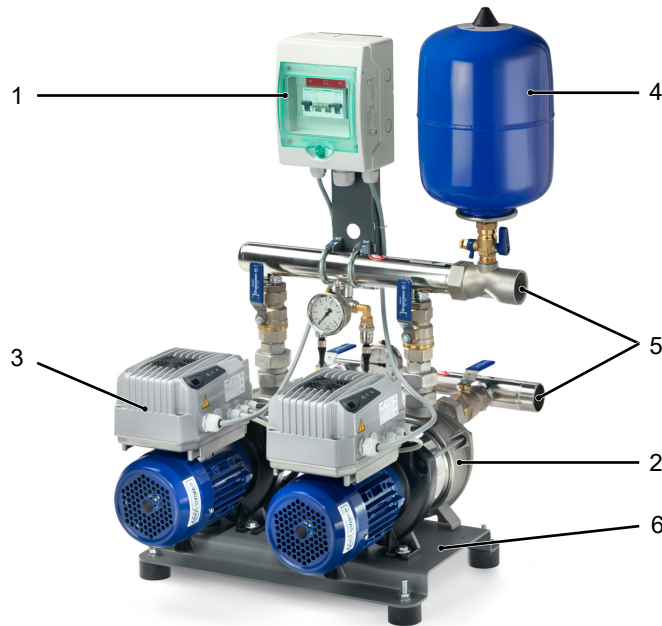

Fig. 2: Illustration of pressure booster system

1	Fuse box
2	Pump
3	Frequency inverter
4	Membrane-type accumulator
5	Manifold
6	Baseplate

Design The fully automatic pressure booster system is equipped with one or more vertical high-pressure pumps (2) (all of which are speed-controlled) for pumping the fluid handled to the consumer installations in the set pressure range.

Function Automatic mode One or more pumps (2) are controlled and monitored by motor-mounted frequency inverters. As the demand increases or decreases, the pumps are started and stopped automatically. As soon as the demand increases again after one pump has been stopped, another pump which has not been in operation before is started up.

The stand-by pump is also included in the alternating cycle.³⁾

The standard setting is for the pressure booster system to start automatically as a function of pressure; the actual pressure is measured by an analog pressure measuring device (pressure transmitter).

As long as the pressure booster system is in operation, the pumps are started and stopped as a function of demand (standard setting). In this way it is ensured that the individual pumps operate only in line with actual demand. The use of variable speed pumps reduces wear as well as the frequency of pump starts in parallel operation.

If a duty pump fails, the next pump is started up immediately. A fault is output, which can be reported via volt-free contacts (e.g. to the control station).

If the demand drops towards 0, the pressure booster system slowly runs down to the stop point and stops

As standard, one of the pumps is on stand-by. The control system defines each of the pumps as stand-by pump in alternation. This prevents stagnation of water in any of the pumps.

³ Multiple pump systems only

**Function
Manual mode**

The pressure booster system is designed with dry running protection.
In manual mode, a minimum flow is required to protect the pump against overheating.

4.7 Noise characteristics

The pressure booster system is available with different numbers and sizes of pumps. For the noise characteristics refer to the operating manual of the pump set. To calculate the expected total sound pressure level, add a defined value to the individual pump set's expected sound pressure level.

Table 9: Values for calculating the total expected sound pressure level

Number of pump sets	Value
	dB(A)
2	+ 3
3	+ 4,5
4	+ 6
5	+ 7
6	+ 7,5

Example Pressure booster system with 4 pump sets (value: + 6 dB(A))

Single pump = 48 dB(A)

48 dB(A) + 6 dB(A) = 54 dB(A)

The expected total sound pressure level of 54 dB(A) may develop when all 4 pump sets are running under full-load conditions.

4.8 Scope of supply

The following items are included in the scope of supply:

Pressure booster system

- 2 horizontal centrifugal pumps with frequency inverters
- Check valve per pump
- Discharge-side, direct-flow membrane-type accumulator
- Integrated dry running protection

Control unit

- Single-phase frequency inverter, motor-mounted

4.8.1 Inlet conditions, version M

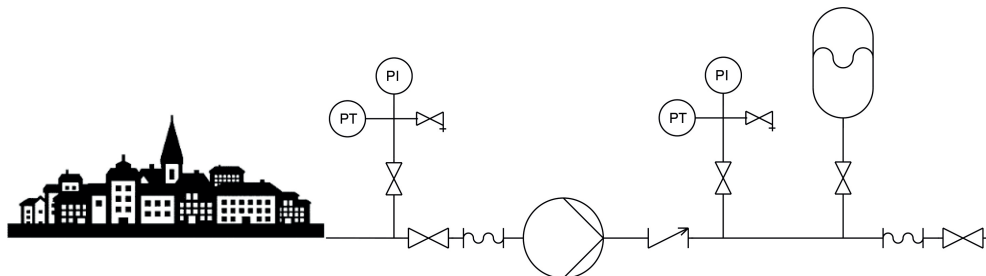

Fig. 3: M = Inlet side of pressure booster system connected to the municipal water supply, suction head operation



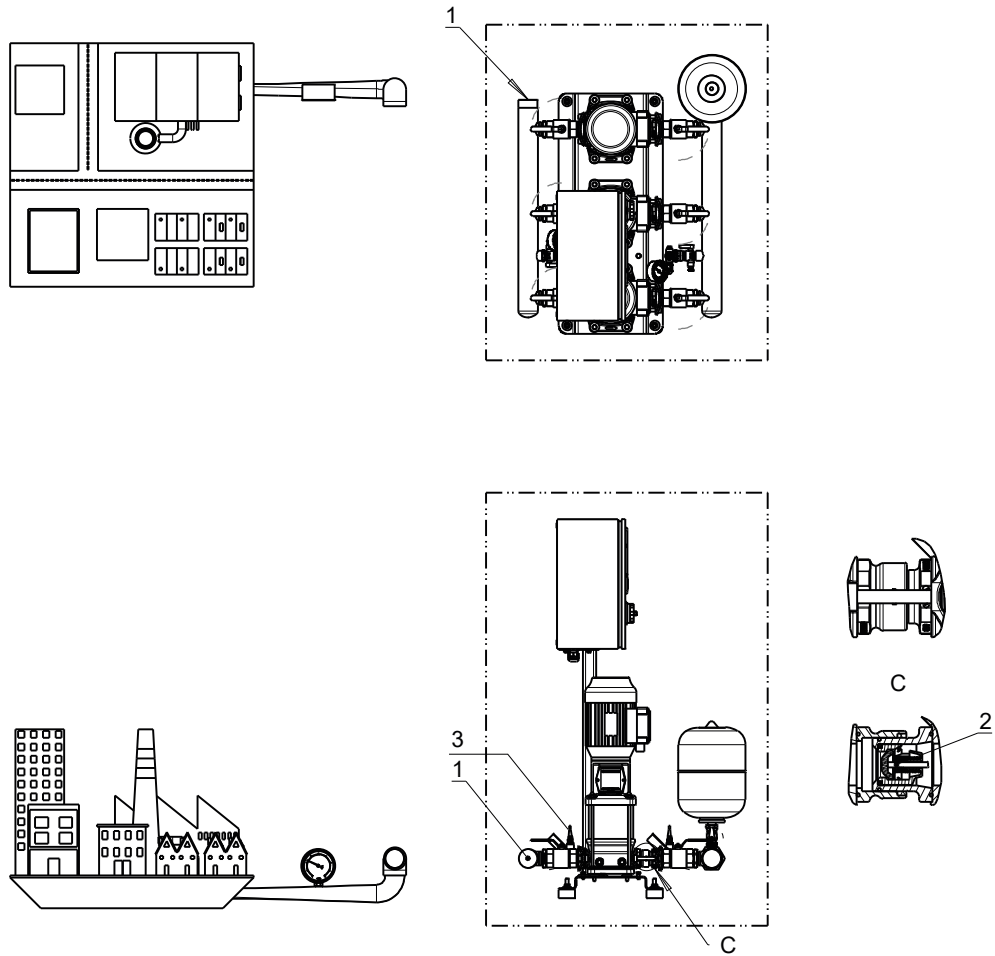

Fig. 4: Scope of supply for version M

1	Suction line (included in DP's scope of supply)
2	Lift check valve (included in DP's scope of supply)
3	Dry running protection (included in DP's scope of supply)

4.8.2 Inlet conditions, version F

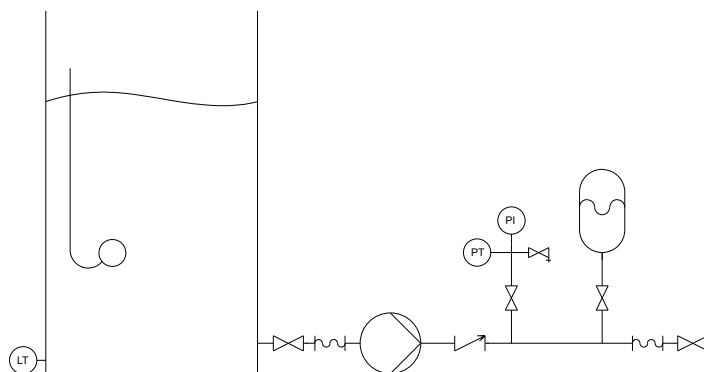

Fig. 5: F = Pressure booster system with break tank arranged on same level as pump, suction head operation

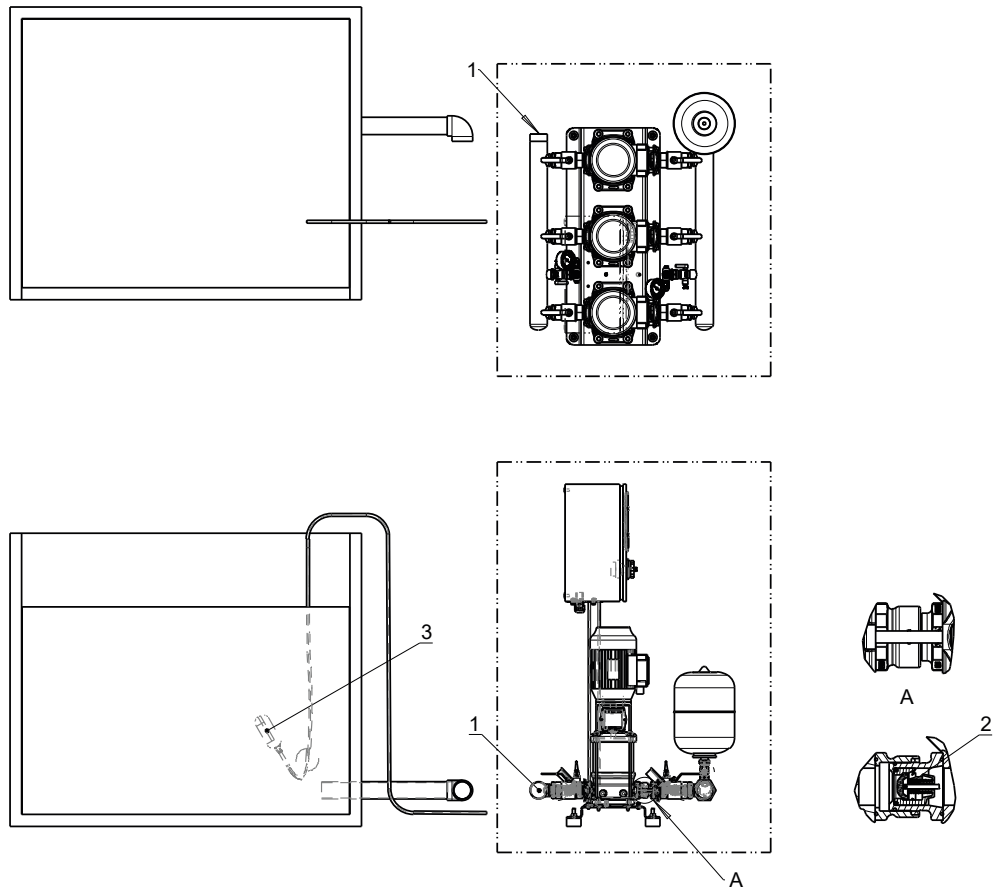

Fig. 6: Scope of supply, version F

1	Suction line (included in DP's scope of supply)
2	Lift check valve (included in DP's scope of supply)
3	Dry running protection (not included in DP's scope of supply)

4.8.3 Inlet conditions, version L

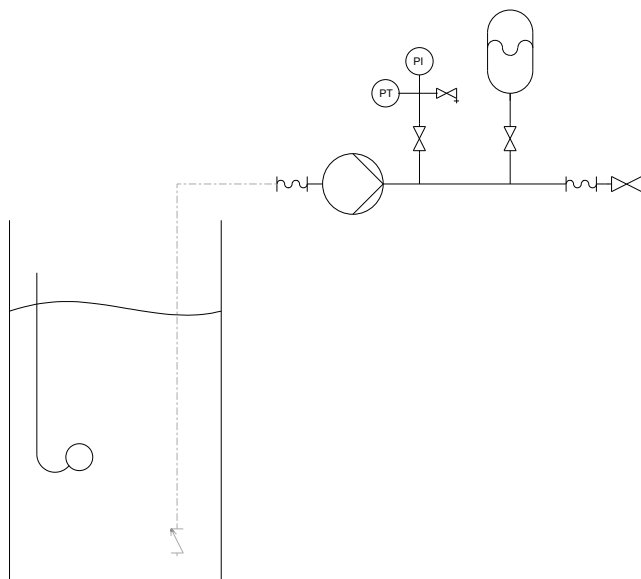

Fig. 7: L = Pressure booster system with break tank arranged at a lower level, suction lift operation

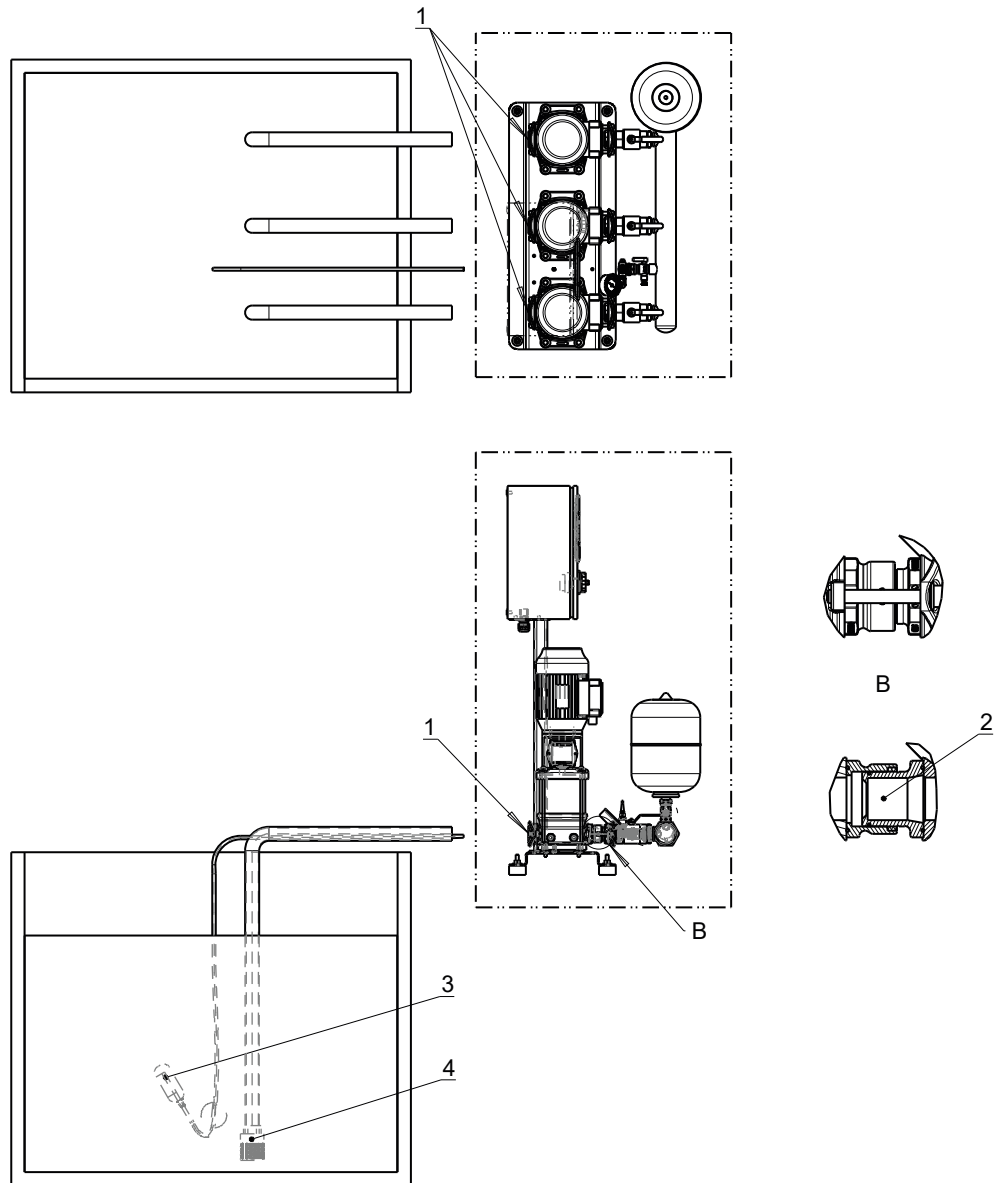

Fig. 8: Scope of supply, version L

1	Suction line (not included in DP's scope of supply)
2	Lift check valve (not included in DP's scope of supply)
3	Dry running protection (not included in DP's scope of supply)
4	Foot valve (not included in DP's scope of supply)

4.9 Dimensions and weight

For dimensions and weights please refer to the type series booklet of the pump (set).

4.10 Terminal wiring diagram

For the terminal assignment refer to the circuit diagram.

4.11 Potential equalisation

A terminal marked with the earth symbol is provided at the power connection for connecting a PE conductor.

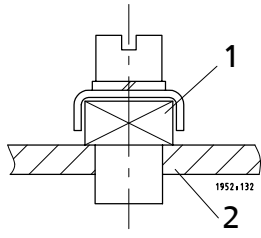

Fig. 9: PE connection

1	Earthing terminal	2	Location of power connection
---	-------------------	---	------------------------------

5 Installation at Site

5.1 Installation



WARNING

Installation on a mounting surface which is unsecured and cannot support the load

Personal injury and damage to property!

- ▷ Use a concrete of compressive strength class C12/15 which meets the requirements of exposure class X0 to EN 206 .
- ▷ The mounting surface must be set, even, and level.
- ▷ Observe the weights indicated.



NOTE

Do not install pressure booster systems next to sleeping or living quarters.



NOTE

The anti-vibration mounts provide adequate insulation against solid-borne noise.

Before beginning with the installation check the following:

- All structural work required has been checked and prepared in accordance with the dimensions in the outline drawing.
- The pressure booster system can be operated on the power supply network in accordance with the data on the name plate.
- The place of installation is frost-free.
- The place of installation can be locked.
- The place of installation is well-ventilated.
- A suitably dimensioned drain connection (e.g. leading to a sewer) is available.
- If expansion joints are used, take note of their creep resistance. Expansion joints must be easily replaceable.

The pressure booster system is designed for a maximum ambient temperature of 0 °C to +40 °C at a relative humidity of 60 %.

5.2 Checks to be carried out prior to installation

Place of installation



WARNING

Installation on a mounting surface which is unsecured and cannot support the load

Personal injury and damage to property!

- ▷ Use a concrete of compressive strength class C12/15 which meets the requirements of exposure class XC1 to EN 206.
- ▷ The mounting surface must be set, even, and level.
- ▷ Observe the weights indicated.



NOTE

The anti-vibration mounts of the pressure booster system provide adequate insulation against solid-borne noise.
Thanks to level-adjustable feet (KSB accessory) the pressure booster system can also be installed in a horizontal position on uneven floors.

1. All structural work required has been checked and prepared in accordance with the dimensions in the outline drawing.

5.3 Installing the pressure booster system



WARNING

Top-heavy pressure booster system

Risk of personal injury by pressure booster system tipping over!

- Pressure booster systems awaiting final installation must be secured against tipping over.
- Firmly anchor the pressure booster system.

Remove all packaging before installing the pressure booster system. Connect the pressure booster system's inlet line and discharge line to the corresponding site distribution lines.



NOTE

To prevent the transmission of piping forces and solid-borne noise, installing expansion joints with length-limiters is recommended.

Allow sufficient space for maintenance and repair work.

- ✓ All structural work required has been checked.
 - ✓ The dimensions of the concrete foundation are correct, and the concrete has set firmly.
1. Mark out the anchoring holes on the floor as shown in the outline drawing.
 2. Drill the holes (max. diameter: 12 mm).
 3. Insert plug fixings of appropriate size.
 4. Place the pressure booster system in its correct installation position.
 5. Use suitable bolts to firmly anchor the pressure booster system.

5.4 Connecting the piping



CAUTION

Air pockets in suction line

Pressure booster system cannot prime!

- Lay the pipe with a continuously rising slope.

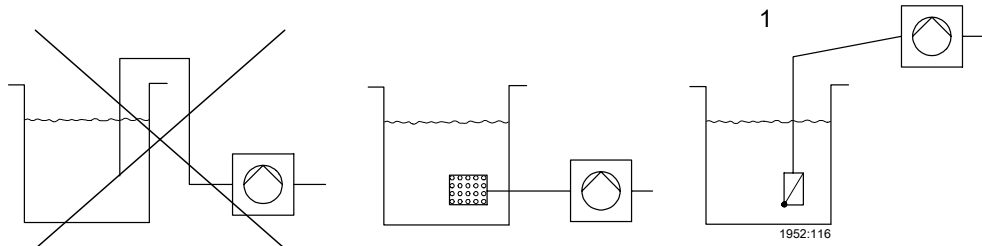

Fig. 10: Correct piping connection

1 | Suction lift operation

1. Mechanically support the suction head line on site to provide for absorption of mechanical forces.
2. Install the piping without transmitting any stresses and strains.
3. Connect the piping to the distribution lines on the inlet side and discharge side.



NOTE

For single-pump systems, the shut-off valves must be fitted directly at the system's suction-side connection and discharge-side connection, respectively. This will enable straightforward replacement and servicing.

5.4.1 Fitting an expansion joint



⚠ DANGER

Sparks and radiant heat

Fire hazard!

- Take suitable precautions to protect the expansion joint if any welding work is carried out.



CAUTION

Wet, contaminated or damaged openings and connections

Damage to the pressure booster system!

- Do not open the pressure booster system openings until just prior to installation.

- ✓ Sufficient clearance in all directions is provided for checking the expansion joint.
 - ✓ The expansion joint is not insulated along with the pipeline insulation.
1. Sufficient clearance in all directions is provided for checking the expansion joint.
 2. Install the expansion joint in the piping free of twist or distortion.
 3. Evenly tighten the bolts crosswise. The ends of the bolts must not protrude from the flange.

5.5 Installing unpressurised inlet tanks

Installation and location of an unpressurised inlet tank together with the pressure booster system are governed by the same rules applicable to the pressure booster system.

Install the closed tank (under atmospheric pressure) available from us as an accessory as described in the installation instructions supplied with the tank.



CAUTION

Dirt in the pressure booster system

Damage to the pump sets!

- Clean the accumulator before filling it.

The tank must be connected mechanically and electrically to the pressure booster system prior to commissioning of the system.

5.6 Electrical connection



⚠ WARNING

Incorrect connection to the mains

Damage to the power supply network, short circuit!

- Observe the technical specifications of the local energy supply companies.

Connection to power supply of the dual-pump systems is effected at the master switch by connecting L1, L2 and N, both for 3~400 V+N, or 1~230 V. Site-supplied fusing: 32 A (max).



NOTE

In individual cases, an earth leakage circuit breaker may trip when the pressure booster system is first commissioned. This may be caused by total discharge of the intermediate circuit.

5.6.1 Sizing the power cable

The cross-section of the power cable must be sized for the total rated power requirement.

5.6.2 Connecting the external dry running protection device (optional)

- ✓ A plug is included in the scope of supply (the pressure booster system has a connection for an external, operator-supplied dry running protection device.)



NOTE

Pressure booster system does not start up

If the pressure booster system is equipped with a connection for an external dry running protection device, an external, operator-supplied dry running protection device must be connected. When the external dry running protection device (e.g. float switch) is not connected, the pressure booster system will not start.

1. Connect the cores of the external dry running protection device at pin 2 and pin 4 of the plug. The contact must be a normally closed contact.

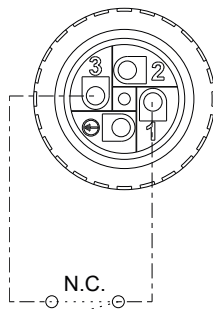

Fig. 11: Connecting the external dry running protection equipment

Table 10: Pin assignment of the plug

Item	Status	Function
1	Normally closed contact	Connected to GND
2	Not used	-
3	Normally closed contact	Connected to DI2
4	Not used	-

6 Commissioning/Start-up/Shutdown

6.1 Commissioning/Start-up

6.1.1 Prerequisites for commissioning/start-up



CAUTION

Pump set running dry

Damage to the pump set/pressure booster system!

- Use dry running protection. If the dry running protection terminal is disabled by means of a bridge, the operator shall assume responsibility for any dry running that might occur.

Ensure that the following requirements are met prior to commissioning/start-up :

- The pressure booster system has been flushed and disinfected in accordance with local requirements.
- The pressure booster system has been properly connected to the electric power supply and is equipped with all protection devices.
- All relevant VDE standards and/or regulations applicable in the country of use are complied with.
- The dry running protection device has been installed.

6.1.2 Commissioning/start-up of pressure booster system



CAUTION

Foreign matter in the piping

Damage to the pump set / pressure booster system!

- Before commissioning/starting up or functional check running the pressure booster system, make sure that there is no foreign matter in the pressure booster system or piping.



NOTE

Commissioning of the pressure booster system - even test running - shall only be carried out in full compliance with all pertinent VDE (German Association of Electrical Engineers) regulations.



NOTE

In individual cases, an earth leakage circuit breaker may trip when the pressure booster system is first commissioned. This is caused by total discharge of the intermediate circuit.

- ✓ The pipe unions between the pump and the piping have been re-tightened.
 - ✓ The cooling air inlet and outlet openings on the motor are unobstructed.
 - ✓ All shut-off valves of the pressure booster system are open.
 - ✓ The pre-charge pressure of the membrane-type accumulator has been checked. [⇒ Section 8.2.3, Page 38]
1. Open or loosen the vent plugs on the pump (refer to the pump's installation/operating manual).
 2. Slowly open the inlet-side shut-off element and prime the pressure booster system until the fluid to be handled escapes through all vent holes.
 3. Insert and slightly tighten the pump vent plugs.

4. Plug in the mains plug or set the master switch to I.
5. Close the discharge-side shut-off element slowly and check whether the pressure booster system stops.
6. Run the pump again, with the discharge-side shut-off element open, and loosen the vent plug to let any remaining air escape.
7. Then re-tighten the vent plug firmly.
8. Verify that the pump is running smoothly.
9. Close the discharge-side shut-off element in order to verify whether the pump reaches its maximum shut-off head.
10. Make sure that the dry running protection device is working properly.



NOTE

Minor leakage of the mechanical seals during commissioning is normal and will cease after a short period of operation.

6.2 Switching on the pressure booster system

Plug in the mains plug or set the master switch to I to energise the pump.
Readiness for operation is signalled by a permanently lit red LED and a flashing green LED.

6.3 Checklist for commissioning/start-up

Table 11: Checklist

Actions	Done	
1	Read the operating manual.	
2	Compare the power supply data against the name plate data.	
3	Check the earthing system (taking measurements).	
4	Check the mechanical connection to the water mains. Re-tighten the flange bolting and pipe unions.	
5	Prime and vent the pressure booster system from the inlet side.	
6	Check inlet pressure.	
7	Check the start-up pressure, re-adjust if necessary.	
8	Test the proper function of the lack-of-water and dry running protection equipment.	
9	Vent the pump for a second time after it has been running for 5 to 10 minutes.	
10	Check the pre-charge pressure.	
11	Record all system conditions that do not correspond to our specifications or to the purchase order in the commissioning report (i.e. inlet pressure + max. pressure of pressure booster system higher than 16 bar).	
12	Complete the commissioning report together with the operator/user and instruct the operator/user as to the function of the unit.	

6.4 Shutdown



NOTE

As long as the system is out of operation, water is supplied directly at inlet pressure p_{inlet} through the pressure booster system.

The pressure booster system remains installed

- ✓ Sufficient fluid handled is supplied for the operation check run of the pressure booster system.
- 1. Pull the mains plug or set the master switch to 0.



DANGER

Voltage at the pressure booster system

Danger to life!

- Prior to opening the device, wait at least 10 minutes for any residual voltage to dissipate.

- 2. Start up the pressure booster system regularly between once a month and once every three months for approximately five minutes during prolonged shutdown periods. This will prevent the formation of deposits within the pump and the pump intake area.

The pressure booster system is removed from the pipe and stored

- ✓ The pressure booster system has been properly drained.
- 1. Spray-coat the inside wall of the pump casings, and in particular the impeller clearance areas, with a preservative.
- 2. Spray the preservative through the suction and discharge nozzles. It is advisable to then close the pump nozzles (e.g. with plastic caps or similar).
- 3. Oil or grease all exposed machined parts and surfaces of the pressure booster system to protect them against corrosion.

6.5 Shutdown

6.5.1 Shutdown

Standard design

- 1. Set the master switch to 0.

Additional instruments

- 1. Set manual-0-automatic selector switch to 0.

6.5.2 Measures to be taken for shutdown

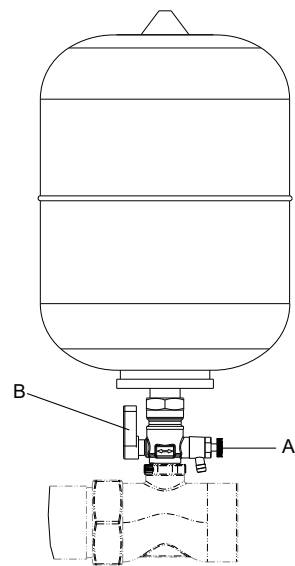

Fig. 12: Venting and draining the accumulator

A	Vent plug
B	Ball valve lever

- ✓ The pressure booster system has been switched off. [⇒ Section 6.5.1, Page 30]
- 1. Turn the ball valve lever B by 45 degrees.
- 2. Open vent plug A at the accumulator.
 - ⇒ The pressure booster system is being vented and drained.
- 3. Close vent plug A at the accumulator.
- 4. Turn the ball valve lever B back into open position (upwards).

7 Operating the Pressure Booster System



CAUTION

Incorrect operation

Water supply is not assured!

- Make sure to comply with all local regulations, particularly the EC Machinery Directive and the EC Directive on Low-Voltage Equipment.

7.1 Design of the frequency inverter



NOTE

An app for connecting with the drive is available to specially trained service staff. The app may be installed via Google Play or App Store.

The frequency inverter is motor-mounted and self-cooling. Its display and control panel feature the following:

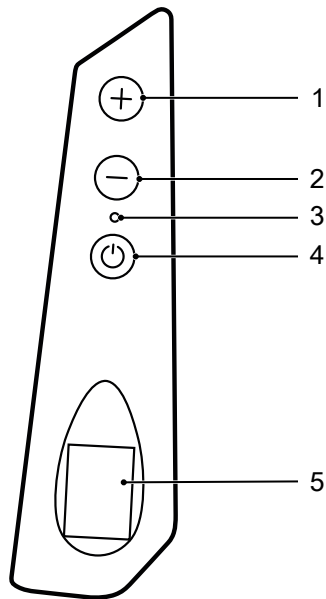

Fig. 13: Buttons and display at the frequency inverter

1	Scrolling through parameters / Adjusting parameter values: The \oplus button can be used to increase the set value or set frequency. To be able to adjust the set value the \oplus or \ominus button has to be pressed for more than 5 seconds until the setting value to be changed starts flashing. To confirm the set value wait for 5 seconds or press the Start/stop button \odot .
2	Scrolling through parameters / Adjusting parameter values: The \ominus button can be used to decrease the set value or set frequency. To be able to adjust the set value the \oplus or \ominus button has to be pressed for more than 5 seconds until the setting value to be changed starts flashing. To confirm the set value wait for 5 seconds or press the Start/stop button \odot .
3	Signal LEDs: Red: The frequency inverter is supplied with the correct supply voltage and is on stand-by. Green: Motor running. Flashing yellow: Alarm condition
4	Start/stop button \odot: Motor start/stop
5	Display: Activating the Start/stop button lock function: Press the Start/stop button \odot for at least 5 seconds. When the Start/stop button lock function is activated, the buttons \oplus and \ominus can be used to scroll through and display the operating parameters. The motor cannot be started or stopped when the Start/stop button lock function is activated. Deactivating the Start/stop button lock function: Press the Start/stop button \odot for at least 5 seconds. Turning the display by 180°: Press the buttons \oplus and \ominus for at least 5 seconds.

7.1.1 Display of the frequency inverter, start view

When the frequency inverter is started up, the control firmware version (LCD=X.XX), the power firmware version (INV =X.XX) and the hardware version (HW =X.XX) are displayed. The start view opens.

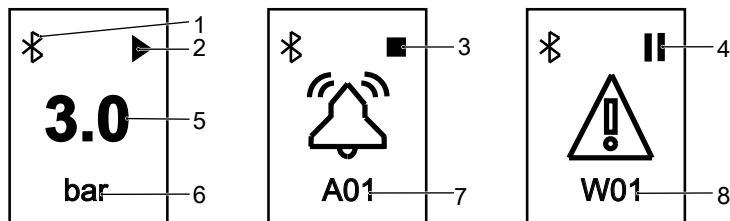

Fig. 14: Display of the frequency inverter, start view

1	Bluetooth active, flashing during communication
2	Motor running
3	Motor stopped
4	Stand-by
5	Read value
6	Measurement unit
7	Alarm
8	Warning

Table 12: Parameterisation

Parameterisation	Description
XX.X [bar]	Measured pressure value
XXX.X [Hz]	Frequency the inverter drives the motor with
XXX [VAC]	Supply voltage of the inverter. This only occurs when the motor is OFF. In ON condition the current input of the motor is shown instead of the supply voltage.
XX.X [A]	Current input of the motor
X.XX [cos ϕ]	Cosine of phase offset ϕ between voltage and current, also referred to as motor power factor
XX.X [kW]	Estimated effective power absorbed by the motor.
X [INV]	Device address if Combo functionality is activated.
AXX	Alarm XX
WXX	Warning XX

7.2 Pressure booster systems with configured frequency inverter drives

Drives supplied as part of the pressure booster system are already configured for operation. The information on default settings is provided for information only; it is only required if the drive needs replacing.

Table 13: Nastec Mida VFD technical data

Model	V_{in}	Maximum V_{out}	Maximum I_{in}	Maximum I_{out}	Motor power P_2
	[VAC]	[V]	[A]	[A]	[kW]
MIDA 203	1~230 +/- 15 %	3~230	5	3	0,55
MIDA 205	1~230 +/- 15 %	3~230	8	5	1,1
MIDA 207	1~230 +/- 15 %	3~230	11	7,5	2,0
MIDA 404	3~380 - 460	$3 \times V_{in}$	3,7	4	1,1
MIDA 406	3~380 - 460	$3 \times V_{in}$	5,4	6	2,2
MIDA 409	3~380 - 460	$3 \times V_{in}$	8	9	4

7.3 Programming

The signal LED lights up in red when the pressure booster system is energised.

Press the Start/stop button ☺ to start up the pump. When the selected setpoint has been reached, the signal LED lights up continuously in green.

Press the Start/stop button ☺ to stop the pump. The signal LED changes from green to red (stand-by status).

Adjusting the pressure







A pressure gauge is fitted in the discharge line. Slightly opening one of the consumer installations facilitates pressure adjustment.

Adjusting the pressure

1. Press the Start/stop button ☺ .
⇒ The pump starts up.
2. **When the Start/stop button lock function is activated:** Press the Start/stop button ☺ for at least 5 seconds.
3. When the Start/stop button lock function is activated, the buttons ⊕ and ⊖ serve to scroll through the operating parameters for the pressure.
4. To be able to adjust the pressure press the ⊕ or ⊖ button for more than 5 seconds until the setting value to be changed starts flashing.
5. Press the ⊕ or ⊖ button to adjust the pressure.
6. **Confirm the set value:** Wait for 5 seconds or press the Start/stop button ☺ .

8 Servicing/Maintenance

8.1 General information/Safety regulations

	<p>⚠ DANGER Unintentional start-up of pressure booster system Danger to life!</p> <ul style="list-style-type: none">▸ De-energise the pressure booster system for any repair work or servicing work.▸ Ensure that the pressure booster system cannot be re-energised unintentionally.
	<p>⚠ DANGER Voltage at the pressure booster system Danger to life!</p> <ul style="list-style-type: none">▸ Prior to opening the device, wait at least 10 minutes for any residual voltage to dissipate.
	<p>⚠ WARNING Improper lifting/moving of heavy assemblies or components Personal injury and damage to property!</p> <ul style="list-style-type: none">▸ Use suitable transport devices, lifting equipment and lifting tackle to move heavy assemblies or components.
	<p>⚠ WARNING Unintentional start-up of pressure booster system Risk of injury by moving parts!</p> <ul style="list-style-type: none">▸ Make sure the pressure booster system has been de-energised before commencing work on the pressure booster system.▸ Make sure that the pressure booster system cannot be started up unintentionally.
	<p>⚠ WARNING Unqualified personnel performing work on the pressure booster system Risk of personal injury!</p> <ul style="list-style-type: none">▸ Always have repair and maintenance work performed by specially trained, qualified personnel.
	<p>CAUTION Incorrectly serviced pressure booster system Function of pressure booster system not guaranteed!</p> <ul style="list-style-type: none">▸ Regularly service the pressure booster system.▸ Prepare a maintenance schedule for the pressure booster system, with special emphasis on lubricants, shaft seals and pump couplings.

The operator ensures that maintenance, inspection and installation are performed by authorised, qualified specialist personnel who are thoroughly familiar with the manual.

- Observe the safety instructions and information.
- For any work on the pump (set) observe the operating manual of the pump (set).
- In the event of damage you can always contact DP Service.
- A regular maintenance schedule will help avoid expensive repairs and contribute to trouble-free, reliable operation with a minimum of maintenance expenditure and work.
- Never use force when dismantling and reassembling the equipment.

8.2 Servicing/inspection

8.2.1 Supervision of operation



CAUTION

Increased wear due to dry running

Damage to the pump set!

- ▷ Never operate the pump set without liquid fill.
- ▷ Never close the shut-off element in the suction line and/or supply line during pump operation.



CAUTION

Impermissibly high temperature of fluid handled

Damage to the pump!

- ▷ Prolonged operation against a closed shut-off element is not permitted (heating up of the fluid).
- ▷ Observe the temperature limits in the data sheet and in the section on operating limits.

While the pump is in operation, observe and check the following:

- If activated, check the functional check run.
- Measure the actual start-up pressure and stop pressure of the pump sets with a pressure gauge. Compare the values with the specifications on the name plate.
- Compare the pre-charge pressure of the accumulator with the recommended data. [⇒ Section 8.2.3, Page 38]
- Check the rolling element bearings for running noises. Vibrations, noise and an increase in current input occurring during unchanged operating conditions indicate wear.
- Monitor the functions of auxiliary connections, if any.

8.2.2 Maintenance schedule

Table 14: Overview of maintenance work

Maintenance interval	Servicing/maintenance work
At least once a year	Check the pump sets for smooth running and the mechanical seal for integrity.
	Check the shut-off elements, drain valves and check valves for proper functioning and tightness.
	If fitted, clean the strainer in the pressure reducer.
	If fitted, check the expansion joints for any wear.
	Verify the pre-charge pressure. Check the accumulator for integrity. [⇒ Section 8.2.3, Page 38]
	Check the automatic switching functionality.

Maintenance interval	Servicing/maintenance work
	Check the cut-in levels and cut-out levels.
	Check the inflow, inlet pressure, dry running protection, flow monitoring and pressure reducer.

8.2.3 Setting the pre-charge pressure



WARNING

Wrong gas

Danger of poisoning!

- Use only nitrogen as cushion gas of the membrane-type accumulator.



CAUTION

Pre-charge pressure too high

Damage to the accumulator!

- Observe the manufacturer's product literature (see name plate or operating manual of the accumulator).

The accumulator's pre-charge pressure (p) must be lower than the set start-up pressure (p_E) of the pressure booster system.

The best storage volumes are achieved with the following settings (mean value):

- Value 0.9 at start-up pressure > 3 bar
- Value 0.8 at start-up pressure < 3 bar

Example 1 $p_E = 5$ bar

$$5 \text{ bar} \times 0.9 = 4.5 \text{ bar}$$

With a start-up pressure of 5 bar the pre-charge pressure of the accumulator must be 4.5 bar.

Example 2 $p_E = 2$ bar

$$2 \text{ bar} \times 0.8 = 1.6 \text{ bar}$$

With a start-up pressure of 2 bar the pre-charge pressure of the accumulator must be 1.6 bar.

Checking the pre-charge pressure

1. Close the shut-off elements fitted underneath the membrane-type accumulator.
2. Drain the membrane-type accumulator via the drain valve.
3. Remove and store the protective cap of the membrane-type accumulator valve.
4. Check the pre-charge pressure using suitable equipment (e.g. tyre pressure gauge).
5. Fit the protective cap of the membrane-type accumulator valve.

Filling the membrane-type accumulator

1. Remove and store the protective cap of the membrane-type accumulator valve.
2. Add nitrogen through the valve.
3. Fit the protective cap of the membrane-type accumulator valve.

9 Trouble-shooting



NOTE

Please contact DP Service before carrying out any work on the pump's internal parts during the warranty period. Non-compliance will lead to forfeiture of warranty cover and of any and all rights to claims for damages.

Table 15: Pump faults

Fault	Possible cause	Remedy	Action
Leakage along the shaft	Worn shaft seal	Replace the shaft seal.	Check the pump for impurities.
	Pump has been operated without water.	Replace the shaft seal.	
Pump does not run smoothly (noise and vibrations).	No water in the pump		Prime and vent the pump.
	No water supply	Re-establish water supply.	Check supply lines for clogging.
	Bearings of pump and/or motor defective	Have bearings replaced by certified company.	
	Hydraulic pump components defective	Replace hydraulic pump components.	
	Wrong direction of rotation of the pump	Interchange two phases of the power supply between frequency inverter and motor. Caution: Prior to opening the device, wait at least 10 minutes for any residual voltage to dissipate.	
System/pump does not start.	No voltage at the terminals	Check power supply.	
	Dry running protection has tripped.	Re-establish water supply. Reset system.	Check that the supply tank is filled with water and that the supply line to the pressure booster system is not clogged.
	Wrong setting of pressure setpoint	Adjust pressure setpoint.	
	Drive fault	Reset drive and note down error code.	
Insufficient flow rate and/or pressure of the system/pump	Air inside the pump	Vent the pump.	
	Wrong direction of rotation of the pump	Interchange two phases of the power supply between frequency inverter and motor. Caution: Prior to opening the device, wait at least 10 minutes for any residual voltage to dissipate.	
	Flow rate of water meter in suction line too low	Increase flow rate of water meter.	
	System-side filter clogged	Clean filter or check filter for obstruction. If required, replace filter.	
	Shut-off valve in outlet and/or inlet closed	Open both shut-off valves.	
	Pumps start and stop too frequently.	Accumulator leakage or wrong pressure setting	
Pump 1 not running, pump 2 running.	Pump 1 has been stopped, and pump 2 has assumed the master function.	Disconnect the system from the power supply. Then re-connect it.	

The yellow alarm LED indicates different alarm messages by flashing at different frequencies followed by a 3-second pause.

Table 16: Error codes of the frequency inverter

Flashing frequency	Description	System re-start
1x	Lack of water. Automatic re-start after 5-10-20-40-80 minutes. The alarm signal starts after the last re-start attempt.	De-energise the system (pull the mains plug or set the master switch to 0). Only after the system has been de-energised can it be re-started.
2x	The maximum motor current is higher than the set limit.	
3x	Sensor alarm (sensor not connected or incorrectly connected, or output current below 2 mA)	
4x	Overheating alarm (temperature at NTC thermistor exceeds 70 °C)	
5x	Frequency inverter alarm (current too high)	De-energise the system (pull the mains plug or set the master switch to 0). Only after the system has been de-energised can it be re-started.
6x	Communication error between master and slaves (check the DIP switch position). Caution: After switching off the frequency inverter, wait 10 minutes until dangerous voltages have discharged.	
7x	The alarm value for the maximum pressure has been reached. (Determine the cause of the maximum pressure exceeding the alarm value).	
8x	The alarm value for minimum pressure has been reached. (Determine the cause of the minimum pressure falling below the alarm value).	
Rapid flashing without any pauses	The digital inputs have been disconnected.	

10 Related Documents

10.1 General assembly drawings/exploded views with list of components

10.1.1 Hydro-Unit Base Line economy MVP

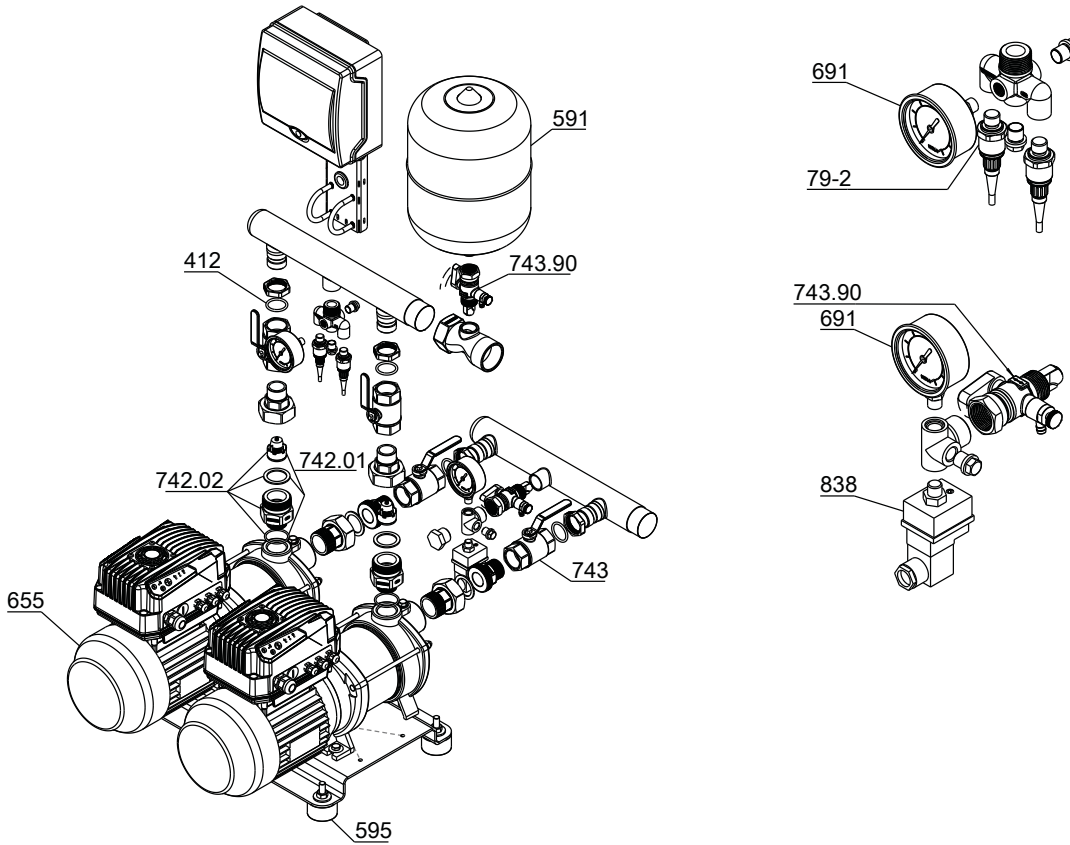

Fig. 15: Base Line economy MVP

Table 17: List of components

Part No.	Description	Part No.	Description
79-2	Measuring transducer	691	Pressure gauge
412	O-ring	742.01/02	Lift check valve
591	Membrane-type accumulator	743/.90	Ball valve
595	Anti-vibration pad	838	Pressure switch ⁴⁾
655	Pump		

The individual parts of the pump set are shown in the product literature of the pump set.

⁴ Optional

11 EU Declaration of Conformity

Manufacturer:

**Duijvelaar Pompen
DP Pumps
Kalkovenweg 13
2401 LJ Alphen aan den Rijn (The Netherlands)**

This EU Declaration of Conformity is issued under the sole responsibility of the manufacturer.

The manufacturer herewith declares that **the product**:

Hydro-Unit Base Line economy MVP

From type number:45/2022 1000000-1

- is in conformity with the provisions of the following directives / regulations as amended from time to time:
 - Pump set: 2006/42/EC Machinery Directive
 - Electrical components⁵: 2011/65/EU Restriction of the use of certain hazardous substances in electrical and electronic equipment (RoHS)
 - 2014/30/EU: Electromagnetic Compatibility (EMC)

The manufacturer also declares that

- the following harmonised international standards have been applied:
 - ISO 12100
 - EN 809
 - EN 60204-1
 - EN 806-2

Person authorised to compile the technical file:

Ron Bijman
Manager Competence Centre Products
Duijvelaar Pompen B.V.
Kalkovenweg 13
2401 LJ Alphen aan den Rijn (The Netherlands)

The EU Declaration of Conformity was issued in/on:

Alphen aan den Rijn, 1 July 2022



Ron Bijman
Manager Competence Centre Products
Duijvelaar Pompen B.V.
Kalkovenweg 13
2401 LJ Alphen aan den Rijn (The Netherlands)

⁵ Where applicable

12 Certificate of Decontamination

Type:

Order number /
Order item number⁶⁾:

Delivery date:

Application:

Fluid handled⁶⁾:

Please tick where applicable⁶⁾:



Corrosive



Oxidising



Flammable



Explosive



Hazardous to health



Seriously hazardous to health



Toxic



Radioactive



Bio-hazardous



Safe

Reason for return⁶⁾:

Comments:

The product / accessories have been carefully drained, cleaned and decontaminated inside and outside prior to dispatch / placing at your disposal.

We herewith declare that this product is free from hazardous chemicals and biological and radioactive substances.

For mag-drive pumps, the inner rotor unit (impeller, casing cover, bearing ring carrier, plain bearing, inner rotor) has been removed from the pump and cleaned. In cases of containment shroud leakage, the outer rotor, bearing bracket lantern, leakage barrier and bearing bracket or intermediate piece have also been cleaned.

For canned motor pumps, the rotor and plain bearing have been removed from the pump for cleaning. In cases of leakage at the stator can, the stator space has been examined for fluid leakage; if fluid handled has penetrated the stator space, it has been removed.

- No special safety precautions are required for further handling.
- The following safety precautions are required for flushing fluids, fluid residues and disposal:

.....
.....

We confirm that the above data and information are correct and complete and that dispatch is effected in accordance with the relevant legal provisions.

.....
Place, date and signature

.....
Address

.....
Company stamp

⁶⁾ Required field



13 Commissioning Report

The pressure booster system specified below has been commissioned today by the undersigned, authorised DP Service who created this report.

Pressure booster system details

Type series
 Size
 Serial number
 Order No.

Purchaser/place of installation

Purchaser	Place of installation
Name
Address
.....

Operating data For further data refer to the wiring diagram.

Start-up pressure p_E bar
 Inlet pressure monitoring $p_{inl} - x$
 (setting of inlet pressure switch)
 Stop pressure p_A bar
 Inlet pressure p_{inl} [bar]
 Pre-charge pressure
 of accumulator $p_{pre-charge}$ [bar]

The operator or operator's representative herewith confirms to have received instructions on how to operate and service the pressure booster system. The relevant circuit diagrams and operating instructions have been handed over.

Non-conformities found during commissioning	Deadline for remedial action
Non-conformity 1.....
.....
.....
.....
Name of DP representative	Name of purchaser or representative
.....
Place	Date
.....

Index

A

Automation 17

C

Certificate of Decontamination 43
Commissioning/start-up 28

D

Design 17
Designation 16
Disposal 14
Drive 17
Dry running protection 28

E

EMC Directive 10
Event of damage 6

I

Installation 17
Installation at site 24, 25
Intended use 8
Interference emissions 10

K

Key to safety symbols/markings 7

M

Maintenance work 37

O

Operating limits 8
Other applicable documents 6

P

Partly completed machinery 6
Personnel 9

Q

Qualification 9

R

Return to supplier 14

S

Safety 8
Safety awareness 9
Scope of supply 19

W

Warnings 7
Warranty claims 6

duijvelaar pompen
dp pumps

Kalkovenweg 13
2401 LJ Alphen aan den Rijn (NL)

† +31 72 48 83 88

www.dp.nl

2023-05-26

BE00001242 (1983.8491/04-EN)

